

15" Industrial Panel PC

PPC-5152-D525-E

15" Flat-bezel Industrial Panel PC

New



**Combo Gigabit LAN
(SFP Fiber/RJ-45)**

Features

- Robust aluminum with IP 64 compliant front bezel design
- 5-wire resistive touch
- Intel® Atom™ D525 1.8GHz dual-core with fan-less design
- 15" 400 nits LED backlight panel with 1024 x 768 resolution
- Two USB 3.0, two USB 2.0 and five COM ports available
- Flexible expansion interface (two PCI slots or one PCI slot + one PCIe slot)
- Dual (10/100/1000BASE-T(X)) gigabit LAN ports



Specifications

Model		PPC-5152-D525-E/R/1G-R10
Display	LCD Size	15"
	Max Resolution	1024(W) x 768(H)
	Brightness (cd/m²)	400
	Contrast Ratio	500:1
	LCD Color	16.2M
	Pixel Pitch (mm) (HxV)	0.1095(H) x 0.1095(V)
	Viewing Angle (V/H)	160° / 140°
	Backlight MTBF (hrs)	50,000
Touch	Touchscreen & Controller	Resistive Type 5-Wire with RS-232 interface / DMC 9000
	Hardness	≥3H (follows JIS K 5600 standard, use Mitsubishi Pencil 500g)
Motherboard	SBC	PPCMB-5152A-D525
	CPU	Intel® Atom™ D525 1.8GHz dual core processor
	Chipset	Intel® ICH8M
	RAM	1*1G 204-pin DDR3 SO-DIMM slot (Max.4GB)
	Ethernet	Realtek RTL8111E PCIe GbE controller supporting ASF 2.0
I/O ports and switches		2 x RS-232 (DB-9 connector) 1 x RS-232 or RS-422/485 (DB-9 connector) 2 x RS-422/485 (RJ-45 connector) 2 x USB 2.0 connector 2 x USB 3.0 connector VGA port (DB-15 connector) AT/ATX switch 2 x RJ-45 Gigabit LAN Reset button
Drive Bay	HDD Drive Bay	One 2.5" SATA HDD/SSD bay
	SSD	CF Type II socket
	CD-ROM Drive Bay	N/A
Physical	Front Panel Construction	Aluminum
	Chassis Construction	Heavy duty steel (SECC)
	Mounting	Panel, Wall, Rack, Stand and Arm (VESA 100 mm x 100 mm)
	Front Panel Color	Silver, Paint Tone PMS 8401C
	Dimensions (WxHxD) (mm)	422 x 331 x 80
	Cut Out Dimensions (WxH) (mm)	390 x 290
Net / Gross Weight		6.5 kg/ 7.0 kg
Expansion Slot		Two PCI slots or one PCI slot plus one PCIe x1 slot
System Cooling		Burglar-proof internal USB 2.0 port Fanless
Environment	Operating Temperature	-20°C ~ 50°C
	Storage Temperature	-30°C ~ 80°C
	Vibration	MIL-STD-810F 514.5C-2 (with CF card or SSD)
	Shock	Half-sine wave shock 3G; 11ms; 3 shocks per axis
	IP level	Front Panel IP 64
	Safety & EMC	CE / FCC
Power	Power Adapter	DSP 90W power adapter (FSP090-D2BA1) Input: 100VAC~240VAC, 50/60Hz Output: 19V DC
	Power Requirement	9~36V DC Jack
	Consumption	50W without add-on card

Ordering Information

	Part No.	Description
15"	PPC-5152-D525-E/R/1G-R10	15" 400 cd/m ² XGA Fanless Panel PC, Intel® Atom™ D525 1.8GHz CPU, 1GB DDR3 RAM, Silver Color, touch screen, ANSI C1D2 SKU
Riser Card	PPCDB-PCI/PCI-E-R10	Riser Card for PCI and PCIe Interface
	PPCDB-PCI-R10	Riser Card, Riser for PCI*2

Options

Item	P/N	Description
Panel Mounting Kit	PK-170M	
Wall Mounting Kit	WK-190MS-R10	
ARM	ARM-11-RS/ARM-31-RS	
Stand	STAND-A19-RS/STAND-A21-R10/ STAND-210-R11	
OS: Win XPE (4GB CF Card)	PPCCF-5152-D525-XPE-4G-R10	
OS: Win 7 Embedded (4GB CF Card)	PPCCF-5152-D525-WES7E-4G-R10	

(*it doesn't include video/audio capture card's driver)

Packing List

Item	P/N	Q'ty	Description
Utility CD	7B000-000732-RS	1	Drivers and user manual
One Key Recovery CD		1	
VESA Mounting Screw	44033-040062-RS	4	M4*6 for securing stand bracket
Chassis Screw	44013-030041-RS	4	M3*4 chassis screw for backup
Capture Card Screw	44003-030062-RS	4	M3*5 capture card screw for backup
VESA Fastener	19Z00-000024-RS	6	
HDD Screw	44043-030051-RS	4	
Pluggable DC-in Terminal Block	33101-000897-RS	1	
RJ-45 to DB9 COM port Cable	32005-000700-100-RS	2	
Touch pen	43125-0002C0-00-RS	1	
IR Remote Controller	7Z000-SLPCB005-RS	1	
Power Adapter	63040-010090-020-RS	1	FSP090-D2BA1;90~264VAC input;90W;19VDC output
Power Cord	32702-000401-100-RS	1	1500 mm, European Standard
Power Transfer Cord	32702-000300-100-RS	1	

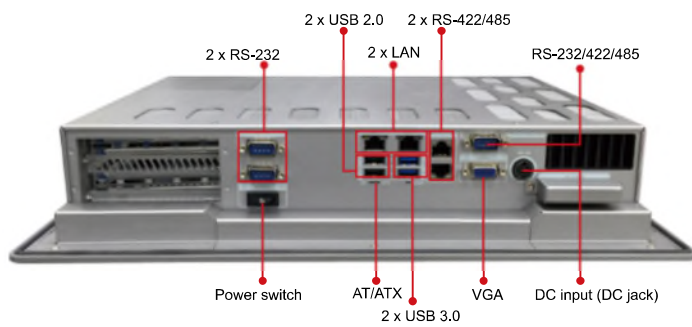

PPC-5152-D525-E Dimensions (Unit: mm)

